

MWPS-72054

24' Pole Utility Building

CAUTION!

Additional professional services will be required to tailor this plan to your situation, including but not limited to: assurance of compliance with codes and regulations; review of specifications for materials and equipment; supervision of site selection, bid letting and construction; and provision for utilities, waste management, roads or other access. **Furthermore, any deviation from the given specifications may result in structural failure, property damage, and personal injury including loss of life.**

WARRANTY DISCLAIMER

This plan provides conceptual information only. **Neither midwest plan service nor any of the cooperating land-grant universities, or their respective agents or employees, have made, and do not hereby make, any representation, warranty or covenant with respect to the specifications in this plan.** Additional professional services will be required to tailor this plan to your situation, including but not limited to: assurance of compliance with codes and regulations; review of specifications for materials and equipment; supervision of site selection, bid letting and construction; and provision for utilities, waste management, roads or other access.

MIDWEST PLAN SERVICE
Cooperative Extension Work in Agriculture and Home Economics and Agricultural Experiment Stations of North Central Region - USDA Cooperating
24' Pole Utility Building
Title Page
MIDWEST PLAN NO. 72054

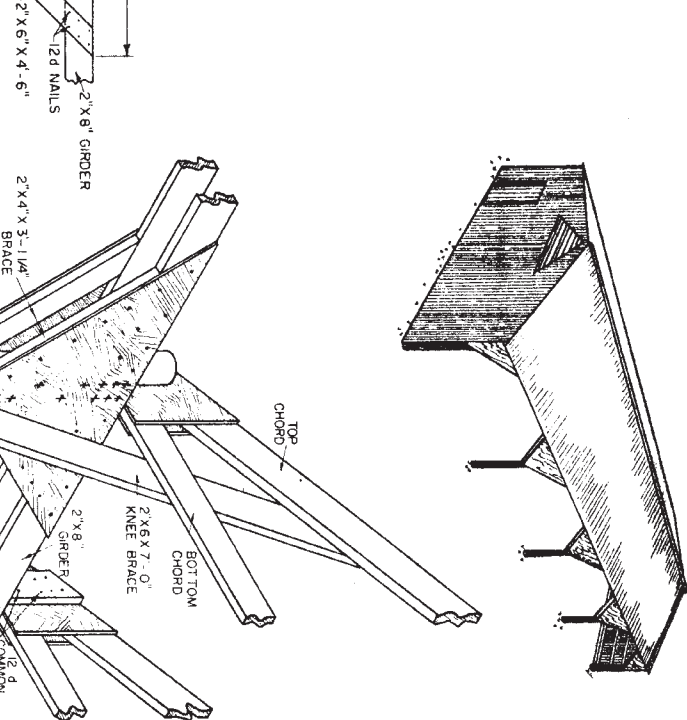
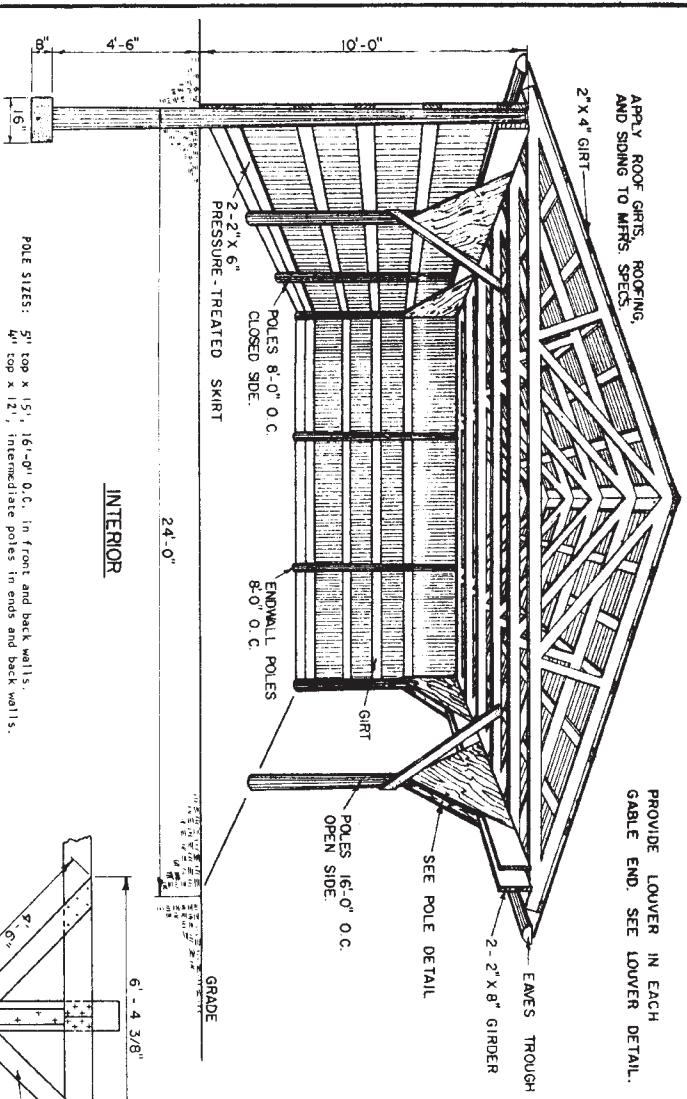

POLE SIZES: 5" top x 1 1/2", 16'-0" O.C. in front and back walls;
 4" top x 1 1/2", intermediate poles in ends and back walls.

REAR WALL CONSTRUCTION - Intermediate 4" top poles in rear wall are non-loadbearing. This construction permits removal of a 4" top pole to make a 16' doorway.
 WALL GIRTS - 2" x 4" wall girts may be spaced up to 2'-0" O.C. Use 2" x 6" girts for greater spacings.

ALL LUMBER IN CONTACT WITH MANURE OR THE SOIL SHOULD BE PRESSURE-TREATED WITH AN OIL-BASE PRESERVATIVE.

ALTERNATE CONNECTION
 THIS JOINT IS MORE CONVENTIONAL, BUT LESS EFFECTIVE THAN THE PIVOT JOINT SHOWN.

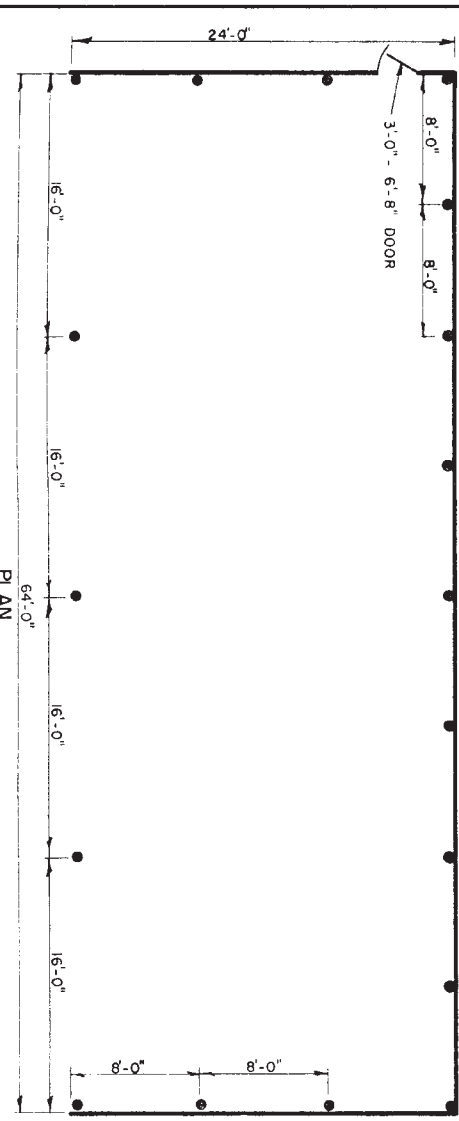
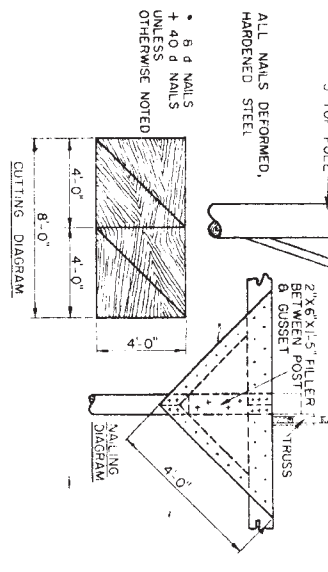

COOPERATIVE EXTENSION WORK IN AGRICULTURE AND HOME ECONOMICS
 NORTH CENTRAL REGION - USDA COOPERATING

24' POLE

MIDWEST PLAN NO. 72054

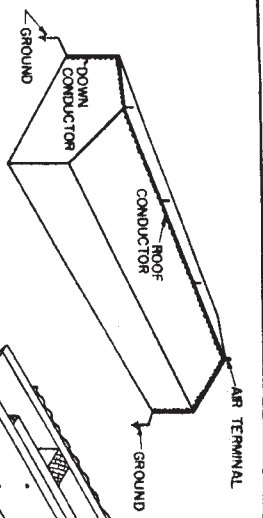

Lightning protection for gable roofs

Air Terminal's
At least 24" long.
Up to 25' apart.

5/8" copper or 5/8" aluminum.
5/8" copper tubing, wall thickness over 0.032"

Conductors:

Copper: 17 AWG wires, 187#/1000'

Aluminum: 14 AWG wires, 95#/1000'

Two down conductors, minimum, on opposite corners.
For bldgs. over 110' long, use one down conductor per 50' add'l length.

Grounds

One ground per down conductor.
Ground rods must be spaced at least 6' apart.

If water pipe enters bldg, bond at least one down conductor to it.

Metal Roofs

Ground metal roofs without air terminals by attaching 18" of conductors to roofing with 2-3/8" J or U bolts. Ground down conductors as with air terminals.

Master Label

For maximum lightning protection obtain a Master Label System as approved by the Underwriters' Laboratories, Inc.

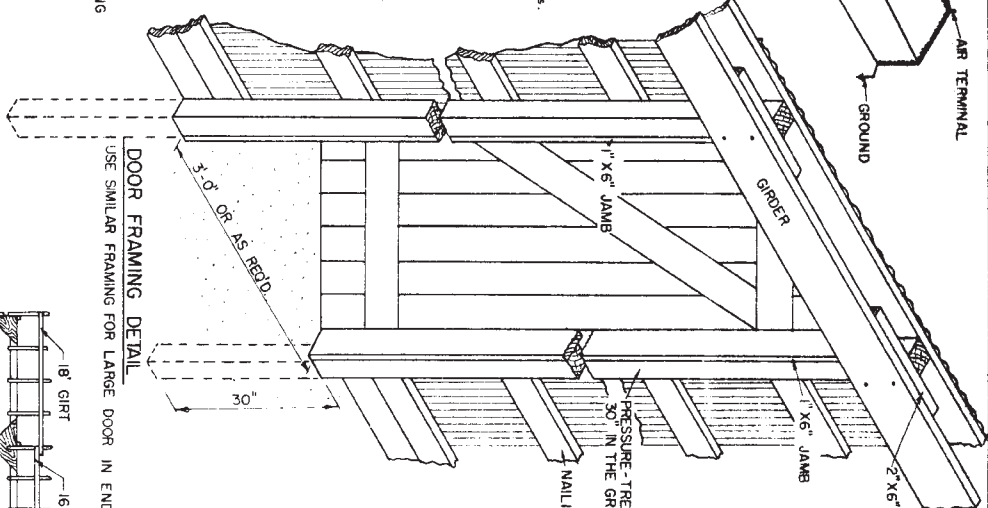

Door framing detail

USE SIMILAR FRAMING FOR LARGE DOOR IN ENDWALL

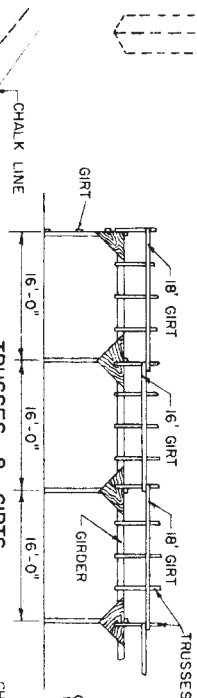

Trusses & girts

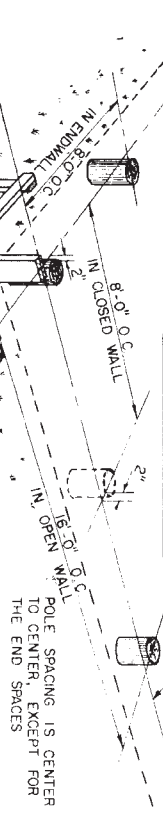

Pole spacing detail

ROOF DECK
SOLID: 1" T & G LUMBER OR EQUIVALENT
SPACED: 2" x 4" GIRTS, LAID FLAT, FOLLOW ROOFING MFR'S SPECS.
ROOFING & SIDING
OPTIONAL. APPLY TO MFR'S SPECS.

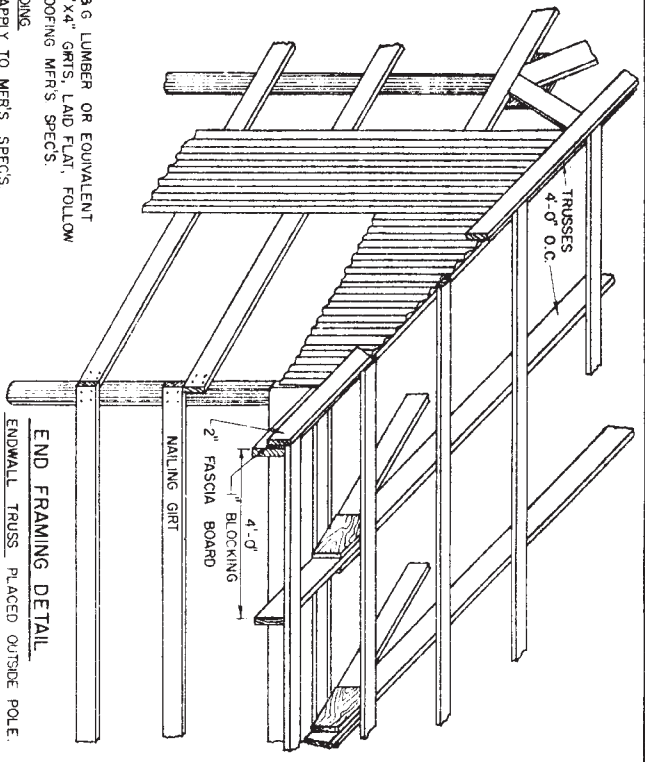

End framing detail

ENDWALL TRUSS PLACED OUTSIDE POLE
NAIL SIDING TO TRUSS MEMBERS

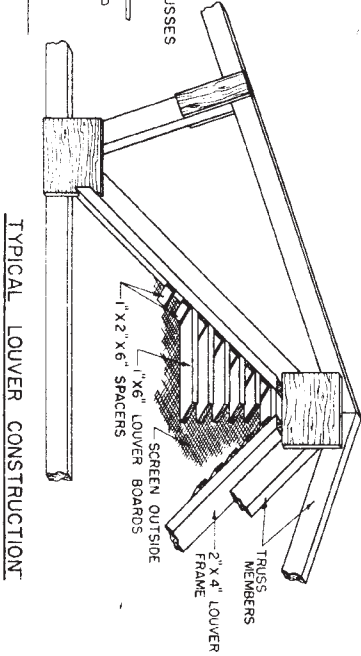

Typical louver construction

Typical window framing

SELECT STOPS & HARDWARE TO SUIT TYPE OF SASH USED

SHEET 3. 24' SPAN TRUSSES

MIDWEST PLAN SERVICE

COOPERATIVE EXTENSION WORK IN AGRICULTURE AND AGRICULTURAL EXPERIMENT STATIONS OF NORTH CENTRAL REGION, USDA COOPERATING

24' POLE

UTILITY BUILDING

SHEET 2 OF 3 SHEETS

MIDWEST PLAN NO. 72054

BUILDING SECTION (16' LONG)

ITEM	DESCRIPTION	BEGINNING NO. FBM	ADDITIONAL NO. FBM	CLOSING NO. FBM
Concrete Poles	Cu. feet 5' Top x 16' 4' Top x 16'	4 4	2 2	2 2
Girders	2"x8"x16'0"	3	1	3
Bracing -	1/2"x4"x8' c-c, Ext. Plywood	4	4	4
	2"x4"x14'0"	1 1/2	1	1/2
	2"x6"x6'0"	3	2	1
	2"x6"x7'0"	2	14	1
Trusses	See Page 3	5	3	4
Girts	2"x4"x16'0"	7	7	7
	2"x4"x18'0"	7	7	7
	2"x6"x16'0"	10	3	10
Skirt Siding	2"x6"x16'0" Pressure-treated	5	2	5
Roofing	Sq. feet	445	160	445
	Sq. feet *	448	448	448
Louwer	Ln. feet Eaves trough	32	32	32
	2"x6"x6'0"	2		2
	1"x6"x10'0"	5		5
	1"x2"x12'0"	1		1
Man door	Sq. ft. screen	15		15
	4"x4"x12'6"	2		2
	2"x6"x2'0"	1		1
	1"x6"x10'0"	11		55

